

BLOWOUT PREVENTER

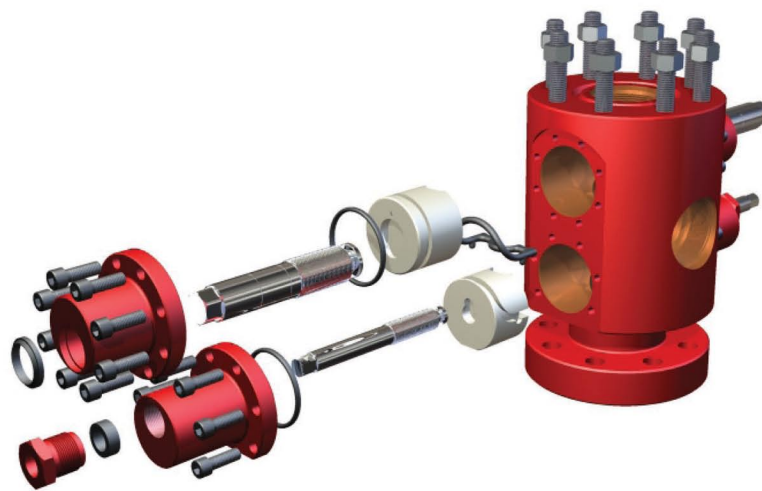

As part of your COMPLETE PCP SYSTEM, **MANTL** is proud to partner with **Domino Machine Inc.** to offer a superior solution for blowout prevention.

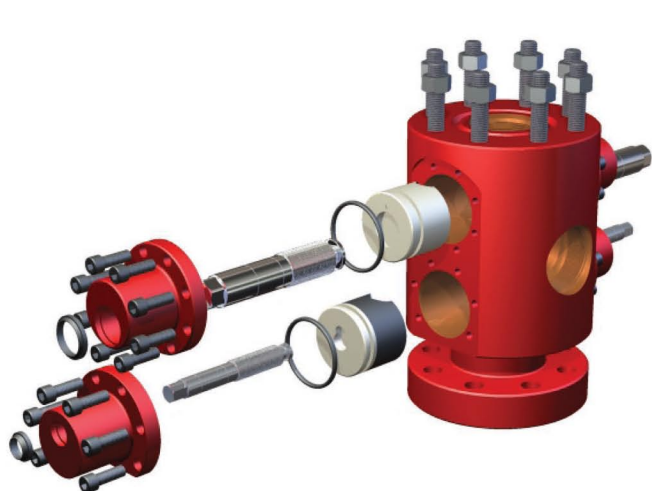

- Integral construction combines tubing bonnet connection, BOP and pumping tee, which reduces leak paths, assembly labor and risk of over-tightened threads
- All steel construction eliminates risk of casting porosity and reduces stack height by 50% compared to traditional assembly
- Suitable for sour, low temperature applications

- LP rams available to close on 0 - 1 1/2" diameter polish rods to 1500 psi working pressure
- HP rams available to close on specified polish rod diameters to 5000 psi working pressure
- Integrated polish rod clamp enhances safety and reduces work over costs
- Clamp rated at 25,000 lbs. polished rod weight with 800 ft-lbs. torque on clamp bolts

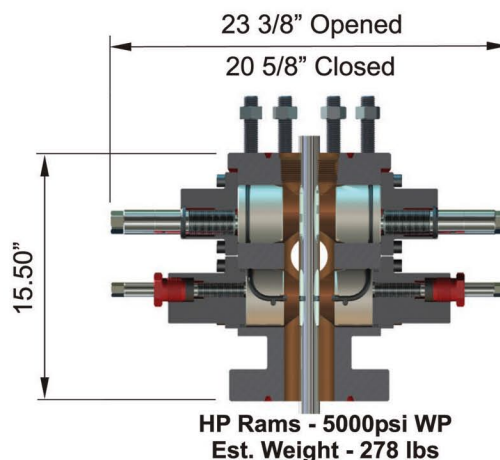
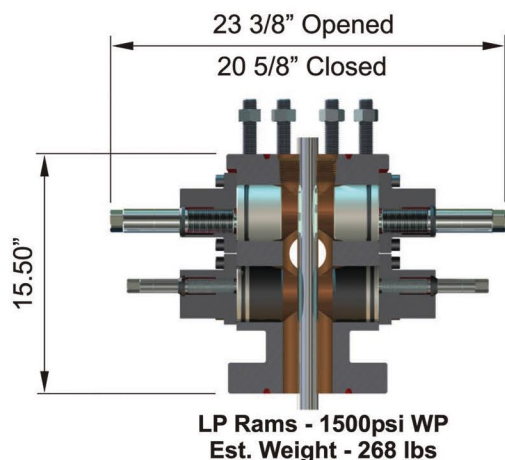

INTEGRAL PRODUCTION BOP WITH POLISH ROD CLAMP 3 1/8" - 3000#
TOP & BOTTOM CONNECTION WITH 3 1/2" - 8RD EUE LIFT THREAD

BLOWOUT PREVENTER



As part of your COMPLETE PCP SYSTEM, MANTL is proud to partner with **Domino Machine Inc.** to offer a superior solution for blowout prevention.

INTEGRAL PRODUCTION BOP WITH POLISH ROD CLAMP

- Universal top connection can be used with any drive head (studded or bolted connection)
- Bottom flange rotates to simplify field tie-in
- All steel construction eliminates casting integrity concerns
- Integrated polish rod clamp enhances safety and reduces work over costs
- Clamp rated at 25,000 lbs. polished rod weight with 800 ft-lbs. torque on clamp bolts

